



## Instructions for Use

### Fibre Optic Fan-Out Kit

Each kit breaks out 6 or 12 individual 250 µm fibers from a loose buffered multifiber tube into individual 900 µm buffer tubes. The fibers can then be terminated using JCS Quick Connectors or Fast Cure Connector termination procedure for 250 µm fibre.

One fan-out kit is required for each loose buffered multi-fiber tube being terminated.



#### Contents (Figure 1):

Top Cover  
6 or 12 Fibre Terminal Assembly Unit  
Base

#### Recommended Tools (not included with Fan-Out Kit):

|                            |                      |
|----------------------------|----------------------|
| Electrical or Masking Tape | Lint Free Wipes      |
| Indelible Marker           | Buffer Tube Stripper |
| Gel Cleaner                | Needle Nose Pliers   |
| Loctite® 411 Adhesive      | Talc Pad             |
| Alcohol Pad                |                      |

#### Determining Strip Length

Locate your work surface as close to the patch panel location as possible, to minimize strip length. Route the cable sheathe through the patch panel to the work surface.

On the cable sheathe (B), measure the length of the fan-out tube plus 6-12". Mark this length with a piece of tape, this is the strip point for the fibre cable sheathe. (Figure 2)

#### Cable End Preparation

Following your cable manufacturer's recommended stripping procedures, strip the cable sheathe back to the tape mark. Secure the cable to the patch panel, then, using lint free wipes, clean any dirt or gel surrounding the loose buffered multifiber tubes (A). (Figure 2)

NOTE: Quantities of loose buffered multifiber tubes may vary among cable manufacturers.

#### Loose Buffered Fiber Tube Preparation

Measure the first loose buffered multifiber tube back 3" longer than your fan-out tube. Mark with an indelible marker, score, and strip, exposing the 250µm fibers (C) inside the buffer tube. Tape the buffered fiber tube to the work surface roughly 2" from the stripped end. (Figure 2) Wipe all gel from the exposed 250µm fibers using a gel cleaner.

Place buffered fibre in the base of the fan-out kit. Using needle nose pliers, press both pairs of the crimping fixture to hold the tube. Crimp only enough to start to deform the tube. Twist and pull the fan-out body to check if the crimp is secure. The tube should not slip or move in the crimp fixture. (Figure 3)

NOTE: For added retention, secure with a few drops of Loctite 411 Adhesive on the crimp points of the fixture.

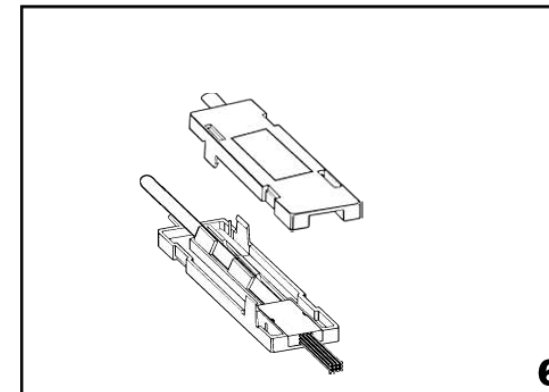
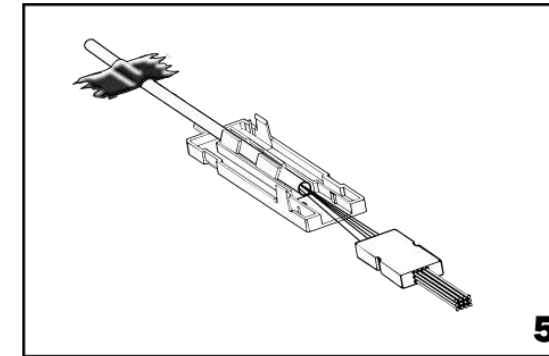
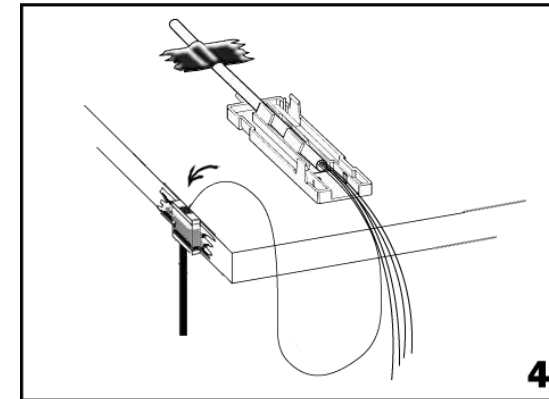
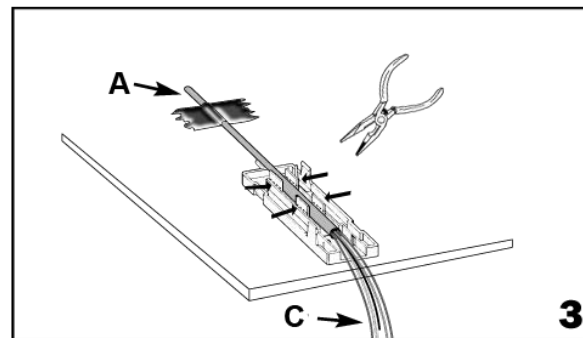
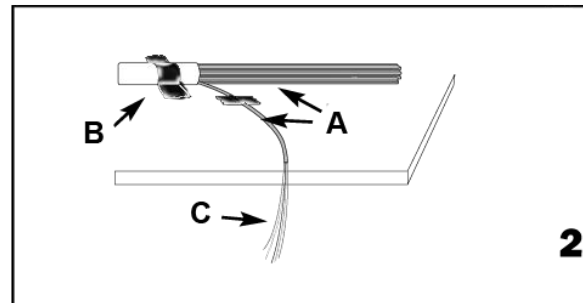
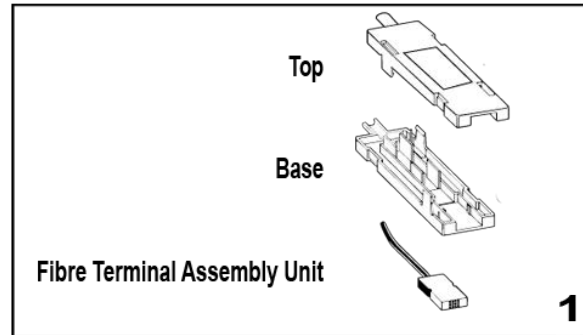

#### Fibre Threading Procedure

Tape the terminal assembly unit in the vertical position, 75mm (3") to the side of the loose buffered fiber tube. (Figure 4)

Untangle the fibers and make sure they are completely free of gel filling compound.

NOTE: Another cleaning method includes talcing the fibers to facilitate the threading. Cup the talc in the palm of your hand and apply along the whole length of the fibers.

Starting with the blue fiber, thread 150mm of the fiber into the corresponding color tube of the terminal assembly unit (Figure 4). Repeat this procedure for the remaining fibers, making sure the color coded fibers match the color coded 900 µm tubing.

When all the fibers have been threaded, push the fibers as a group until they start to protrude from the end of the 900 µm fan-out tubes. Gently pull the fibers through the tubing, leaving sufficient slack so the fibers are not stressed. DO NOT PULL TAUT.

NOTE: While threading fibers through the 900 µm tubing, gently pull the tubing straight with one hand to remove any coil.

Untape the terminal assembly unit and slide the assembly toward the loose buffered fiber tube while pulling the fibers from the end of the 900 µm tubing. If the fibers twist, rotate the terminal assembly in the opposite direction of the twist. (Figure 5)

Place the terminal assembly unit into the mating feature in the base. Align the top cover and snap into place (Figure 6). Remove the tape from the loose buffered fiber tube and repeat this procedure for any remaining loose buffered multifiber tubes.

#### Termination:

Connectorize each fiber following the connector assembly instructions.

#### Patch Panel Installation:

Hold the Fan-Out Kit and buffered fiber together at the point where the tube enters the Fan-Out Kit, then place the Fan-Out Kit and excess buffered fiber into the patch panel.

## SAFETY AND INSTALLATION INSTRUCTIONS

1. Always wear safety glasses when working with fibre optic cable.
2. Never look directly into a laser light source.
3. Always dispose of fiber debris properly.
4. No food or beverages in the vicinity.

## IMPORTANT INSTRUCTIONS

1. Read and understand all instructions.
2. Follow all warnings and instructions marked on the product.
3. SAVE THESE INSTRUCTIONS.

LOCAL MANUFACTURE, SERVICE AND SUPPORT

JCS TECHNOLOGIES PTY LTD | [www.jcstech.com.au](http://www.jcstech.com.au) |

T: +61 2 8878 6600 | F: +61 2 9808 2622 | E: [sales@jcstech.com.au](mailto:sales@jcstech.com.au)